

Tunbridge Wells Borough Council

Street trading policy

Schedule 4 of the Local Government
(Miscellaneous Provisions) Act 1982

October 2013



Contents

1. [Introduction scope and purpose](#)
2. [Definition of street trading](#)
3. [Prohibited streets](#)
4. [Consent streets](#)
5. [Policy considerations](#)
6. [Site assessment](#)
7. [Sustainability and product type](#)
8. [Hours of operation](#)
9. [Suitability of trading unit](#)
10. [Suitability of applicant](#)
11. [Submitting an application](#)
12. [How the Council makes its decision](#)
13. [Request for a review to a Licensing Sub-Committee](#)
14. [Duration of permissions and fees](#)
15. [Conditions/Compliance/Enforcement](#)

Appendices

[Appendix A](#) – Town centre – Consent and prohibited streets in the Borough

[Appendix B](#) – List of Consent and Prohibited streets in the Borough

[Appendix C](#) – Calverly Precinct – Location of market stall pitches

[Appendix D](#) – Street trading Consents. Guidelines on the relevance of convictions/cautions/warnings

[Appendix E](#) –Street trading fees

[Appendix F](#) –Standard conditions that will normally be attached to street trading consent

1.Introduction scope and purpose

1. Local Authorities have a legal discretion to regulate street trading in their area. If they exercise their discretion, they can apply controls across the whole of their administrative boundary or just parts of it. In the early 1980's Tunbridge Wells Borough Council, herein referred to as "The Council" adopted the provisions of Schedule 4 of the Local Government (Miscellaneous Provisions) Act 1982.
2. The Council agreed to regulate street trading in certain parts of the town centre, predominantly in the central area or in other areas where street trading activity would be considered inappropriate.
3. The purpose of this Street Trading Policy is to provide a decision-making framework for the consideration of applications for street trading consents.
4. This Policy aims to create a street trading environment which complements premises-based trading, is sensitive to the needs of residents and businesses, provides diversity and consumer choice. It seeks to enhance the character, ambience and safety of the local environment.
5. The Council's ability to regulate street trading is set out in Schedule 4 of the Local Government (Miscellaneous Provisions) Act 1982 referred to in this Policy as "the Act".

2.Definition of street trading

1. Street Trading is defined in paragraph 1 of Schedule 4 of the Local Government (Miscellaneous Provisions) Act 1982 as:

“the selling or exposing or offering for sale of any article (including a living thing) in a street”.
2. The Act defines the term “street” as including:

“any road, footway, beach or other area to which the public have access without payment”; and a service area as defined in Section 329 of the Highways Act 1980”.
3. Any part of a street is a “street” for the purposes of the Act.
4. The Act at paragraph 1(2) of Schedule 4 states that the following types of trade are not street trading:
 - a. a pedlar trading under the authority of a pedlar's certificate granted under the Pedlar's' Act 1871;

- b. anything done in a market or fair, the right to hold which was acquired by virtue of a grant, enactment or order;
 - c. trading in a trunk road picnic area provided by the Secretary of State under Section 112 of the Highways Act 1980;
 - d. trading as a News Vendor;
 - e. trading carried on at premises used as a petrol filling station;
 - f. trading carried on at premises used as a shop or in a street adjoining a shop where the trading carried on is part of the business of the shop;
 - g. selling things, or offering or exposing them for sale, as roundsmen.
5. For the purposes of street trading activity, streets are designated as either ‘**prohibited**’, or ‘**consent**’ streets. The location of prohibited and consent streets in Tunbridge Wells are contained in the list at appendix A
6. A map of the town centre area defined in this policy is included in appendix B. A definition of the different classifications is set out below:

3. Prohibited streets

1. If a street is designated as a “**prohibited street**” then a criminal offence is committed by any person engaging in street trading in that street. There could be a number of reasons for wishing to designate a street as prohibited. For example, the street may not be wide enough to facilitate a trader or the Council may wish to restrict trading at a particular location.

4. Consent streets

1. If a street is designated as a “**consent street**”, then street trading without a consent is a criminal offence. The Council is bound to act reasonably and consistent with its general obligations, for example those under the Human Rights Act 1998.
2. However, subject to this, the Council enjoys a very wide discretion with regard to the granting or refusal of street trading consents. It does not have to rely upon specific statutory grounds in order to refuse an application for grant or renewal of a consent. This may include:
- a. That there are sufficient traders in the locality;

- b. The proposed operation is likely to cause noise, nuisance or disturbance
 - c. There is insufficient space for trading to take place
3. There is no statutory right of appeal against any Council decision made in respect of a street trading, although in theory a demonstrably unreasonable decision could be challenged by way of judicial review. A street trading consent can only be granted for a period not exceeding twelve months and can be revoked at any time.
 4. When granting or renewing a consent, the Council may attach any reasonable conditions to it. The Council may, at any time, vary the conditions attached to a consent.
 5. Any such variations will be notified in writing to the named person on the application, and to whom the consent has been approved, and will take effect immediately, or on the date contained within the notification letter.

5. Policy considerations

This Policy facilitates the administration of applications for street trading consents. Central to the Council's policy are a number of objectives which are set out below:-

1. **Public Safety:** The proposed location of the activity should not present a significant risk to the public in terms of highway safety and obstruction. This would include the consideration of factors such as interference with sight lines for road users, and pedestrian access including access for the disabled. The views of the Highway Authority have been sought in this regard and are contained within the Council's street trading terms and conditions at appendix F.
2. **Commercial Issues:** Consideration will be given to the number of other traders in the vicinity of the application site and whether the street trading proposed is for a similar type of product or offer. The Policy aims to protect against the over proliferation of street traders and is mindful of the impact such can have in an existing retail area or other localised issues. Unless street trading activity forms part of an authorised street market/event or is taking place within one of the five designated pitches within the Calverley Precinct, no more than one street trader shall be permitted to operate in a consent street at any one time.
3. **Prevention of Crime and Disorder:** The proposed activity should not present a risk to crime, disorder or give rise to anti-social behaviour and related nuisance. This is likely to be more of an issue in respect of applicants wishing to trade in the later hours, or where the area is a crime hotspot or has an issue with anti-social behaviour and nuisance.

4. **Prevention of Public Nuisance:** Consideration will be given to measures taken to reduce the risk of nuisance from noise, refuse, vermin, fumes and smells. The street trader shall be personally responsible for the removal and disposal of any waste created by that activity. He/she shall return the area back to its original condition at the conclusion of each trading occasion.

6. Site assessment

1. The Council will identify suitable pitches for street trading and will also consider applications from individuals to create new pitches in specific locations if the applicant can demonstrate a clear demand for the goods or service to be provided.
2. In determining whether to create a street trading pitch, the Council will have regard to:
 - a. Any effect on road safety, either arising from the siting of the pitch or from customers visiting or leaving;
 - b. Any loss of amenity caused by noise, traffic or smell;
 - c. Existing traffic orders;
 - d. Any potential obstruction of pedestrian or vehicular access, for example where the road by its overall design makes street trading unsuitable, it is narrow or one way;
 - e. Any obstruction to the safe passage of pedestrians;
 - f. The safe access and egress of customers and staff from the pitch and immediate vicinity;
 - g. The proximity of such to business and/or residential accommodation where is likely to cause noise, nuisance or disturbance; and
 - h. Any planning restrictions.
3. Within the Calverley Precinct there shall be 5 designated street trading pitches as detailed in appendix C. The size of one pitch shall be no more than 3.6 metres by 1.2 metres in size.
4. Trading from all other consent streets within the borough are subject to Planning restrictions and trading is only permitted on a maximum of 28 days per calendar year without the necessary planning permission.

5. The Borough Council or Kent County Council as the Highway Authority will reserve the right to suspend any of these pitches at any time to accommodate works on the highway, or to facilitate other street scene activity.

7. Sustainability and product type

1. The applicant should set out measures to reduce the environmental impact of the proposed activity. Typically, this could include the use of recyclable products and energy efficient processes. Consideration will also be given to the type of products sold, and the suitability of the products at the location requested, particularly where there are established outlets selling similar products. The sale or supply of live animals shall be strictly prohibited.
2. In general, street trading consents will not be granted where the product to be traded is similar to products sold within existing outlets in the direct vicinity. Goods will normally consist of craftwork, fresh flowers and foodstuffs. Other types of trading, including the provision of services will be considered on a pitch by pitch basis.

8. Hours of operation

1. Street trading hours to be agreed on a pitch by pitch basis at the initial application stage.

9. Suitability of trading unit

1. The motor vehicle, trailer or stall to be used will be of a high-quality design/build and will add to the quality of the street scene. It will be approved by the Council's Senior Licensing Officer and will be inspected by Authorised Officers of Tunbridge Wells Borough Council prior to any consent or licence being issued.
2. Motor vehicles are not permitted on Calverley Precinct.
3. This list is not exhaustive, but it includes the following legislation, and any subsequent revisions: -
 - a. Food Premises (Registration) Regulations 1991
 - b. Food Safety Act 1990
 - c. Food Safety (General Food Hygiene) Regulations 1995 (as amended)
 - d. The Food Safety (Temperature Control) Regulations 1995

- e. Health and Safety at Work etc Act 1974 and any regulations made under this Act
 - f. Environmental Protection Act 1990
 - g. Licensing Act 2003
4. A pitch is defined as an area of space measuring no more than 3.6 metres by 1.2 metres (excluding canopy) per trading unit for Calverley Precinct. Where this is exceeded, the Council may take enforcement action. See [Conditions/Compliance/Enforcement](#).
5. The size of a pitch for trading at an authorised street market/event in Calverley Precinct or any of the other consent streets will be determined by officers on its merits. If this size is exceeded, the Council may take enforcement action. See [Conditions/Compliance/Enforcement](#).

10. Suitability of applicant

1. When determining an application for the grant of a street trading consent, the Council will consider all relevant information relating to the suitability of the applicant to hold such a permission. Applicants are advised to familiarise themselves with the Street Trading “Guidelines on the Relevance of Convictions / Cautions / Warnings” policy before making an application for a [Consent](#). See appendix D.

11. Submitting an application

1. Application forms are available from

Tunbridge Wells Borough Council
Licensing department
Town Hall
Royal Tunbridge Wells
Kent
TN1 1RS
E mail: licensing@tunbridgewells.gov.uk

Telephone: 01892 526 121

2. The following will be required to be submitted with the application: -
 - a. A completed and signed application form.
 - b. The application fees.
 - c. Where the proposed activity will take place at a fixed position, a map of at least 1:200 scale should be submitted clearly identifying the proposed location by marking the site boundary with a red line.
 - d. Two colour photographs of the trading unit illustrating different elevations of the unit.
 - e. A copy of the certificate of insurance covering third party and public liability risks to the level of £5 million.
 - f. Two colour passport photographs of the applicant.

12. How the Council makes its decision

1. Officers will determine each application on its merits, but will, in particular, have regard to the four policy objectives located at paragraph 5.0.
2. In the event of a street trading consent being refused, there is no right of appeal. However, this Council will, where it considers appropriate, offer the right to request a review by a Licensing Sub-Committee. When an application is refused, the fee will be refunded.
3. When the determining officer refuses an application, the applicant will be informed in writing of the decision and the right to request a review by a Licensing Sub Committee, within 10 working days.

13. Request for a review to a Licensing Sub-Committee

1. The Sub-Committee will consist of three elected Members of the Licensing Committee. These meetings are normally held in public unless there are matters to be considered that are of a confidential nature.
2. On receipt of the Request for a Review, arrangements will be made for the case to be heard by the Sub-Committee.

3. The applicant will be invited to attend the hearing and will be given the opportunity to address the Committee and ask any questions pertinent to the application. The applicant can be represented by a solicitor or supported by a friend or colleague.
4. The Sub-Committee will always determine the appeal by:
 - a. Considering each case on its merits;
 - b. Using this Policy to assess applications where appropriate;
 - c. Dealing with the hearing in a balanced and impartial manner;
 - d. Ensuring that the rules of natural justice are applied; and
 - e. Giving all parties sufficient opportunity to present their case, ask questions and present information in support of their application.

14. Duration of permissions and fees

1. A consent may not be valid for more than 104 days in a calendar year, per stall, per applicant. Street trading consents will be issued for up to a maximum of 104 days in any calendar year: per
 - a. Day
 - b. Month
 - c. Quarter
 - d. 6 months
 - e. Year
2. All fees must be paid in full in advance, otherwise the application will be deemed invalid. A list of the [fees](#) and charges is included at Appendix E.
3. If a consent is revoked or surrendered, no refund of the fee will normally be made.
4. Where a consent has been approved for a particular individual or operation, this does not set a precedent, nor create an entitlement that that individual will be granted permission for that, or another location within a consent street, in the future.

15. Conditions/Compliance/Enforcement

1. [Standard conditions](#) are contained at Appendix F. These will be attached to -each consent. These conditions include details regarding the holder's responsibility to maintain public safety, prevent nuisance, and to preserve local amenities.
2. Further conditions may also be attached, limiting the days and the hours when street trading is permitted, the goods which may be sold, the size of the trading pitch or any other matter the Council deems appropriate.
3. Failure to comply with conditions may lead to revocation of a consent.
4. Persons engaging in street trading (as defined in the Act) without a consent or who fail to comply with the conditions will be liable to prosecution under paragraph 10 of Schedule 4 of the Act.
5. Decisions regarding enforcement action will be made in accordance with the Licensing Enforcement Policy adopted by the Council.

Appendix A - Town centre Consent and Prohibited streets in the Borough

1. Many of the streets in the Borough of Tunbridge Wells are designated as “**consent streets**”, where, subject to the necessary consent being in place, street trading is permitted. Several are defined as “**prohibited streets**” where street trading of any type is prohibited.
2. With the exception of authorised street markets/events taking place in the Town Centre, the Council limits the number of pitches from which street trading can take place in any consent street.
3. There shall be 5 designated street trading pitches within Calverley Precinct which will be offered on a rotational basis, for a period to be determined by the Council’s Senior Licensing Officer: each application will be considered on its merits. The Council reserves the right to suspend these pitches at any time to accommodate works on the highway, or to facilitate other street scene activity.
4. The size of one pitch shall be no more than 3.6 metres by 1.2 metres in size and will be located as follows:
 - Pitch 1 - 35-39 Calverley Road
 - Pitch 2 - 41-43 Calverley Road
 - Pitch 3 - 44 Calverley Road
 - Pitch 4 - 48 Calverley Road
 - Pitch 5 - 50 Calverley Road
5. All streets which are designated as a classified “**A Road**”, and/or where the speed limit for that road exceeds 30 miles per hour are “**Prohibited Streets**”. No street trading is permitted in a prohibited street.
6. Where a street is awarded consent status, any applications will be considered within the context of the broader Street Trading Policy.

Appendix B – List of Consent and Prohibited streets in the Borough (Consent streets in bold)

Road name	Description of area covered	Consent or prohibited?
Belgrave Road	For its entire length	Prohibited
Calverley Road	Between its junctions with Mount Pleasant Road and Camden Road	Consent
Calverley Street	From its junction with Calverley Road to its junction with Garden Street	Prohibited
Camden Road	Between its junctions with Quarry Road and Garden Road	Consent
Crescent Road	‘Consent Street’ only from its junction with Mount Pleasant Road to its junction with Calverley Park)	Consent
Castle Road	For its entire length	Consent
Castle Street	For its entire length	Consent
Chapel Place	For its entire length	Prohibited
Church Road	From its junction with Inner London Road to its junction with Mount Pleasant Road	Consent
Culverden Street	For its entire length	Prohibited
Dudley Road	For its entire length	Prohibited
Eridge Road	From its junction with London Road to its junction with Montacute Gardens	Prohibited
Eridge Road	From its junction with Linden Park Road to its junction with Montacute Gardens	Prohibited
Eridge Road	From its junction with Nevill Street to its junction with Linden Park	Prohibited
Garden Street	For its entire length	Prohibited
Goods Station Road	For its entire length	Prohibited

Road name	Description of area covered	Consent or prohibited?
Grove Hill Road	From its junction with Mount Pleasant Road to Sutherland Road	Prohibited
Grosvenor Road	For its entire length	Prohibited
Hanover Road	For its entire length	Prohibited
High Street	For its entire length	Consent
Lime Hill Road	For its entire length	Prohibited
Little Mount Sion	For its entire length	Prohibited
London Road, Royal Tunbridge Wells	From its junction with Nevill Street in a northerly direction to its junction with the High Street	Consent
Market Street	For its entire length	Prohibited
Meadow Road	For its entire length	Prohibited
Mount Pleasant Avenue	For its entire length	Prohibited
Mount Pleasant Road	For its entire length	Consent
Monson Road	For its entire length	Consent
Mount Sion	For its junction with High Street to Cumberland Walk	Prohibited
Mount Ephraim	From its junction with London Road to St John's Road junction	Prohibited
Newton Road	For its entire length	Prohibited
Nevill Street	From its junction with the Sussex Mews in a northerly direction	Consent
Quarry Road	From its junction with Albion Road and Western Road	Prohibited
Rock Villa Road	For its entire length	Prohibited

Road name	Description of area covered	Consent or prohibited?
Upper Grosvenor Road	From its junction with Grosvenor Road to a point ten metres north east of its junction with Meadow Road	Prohibited
Vale Road	For its entire length	Consent
Victoria Road	For its entire length	Prohibited
White Bear Passage	For its entire length	Prohibited
York Road	For its entire length	Prohibited

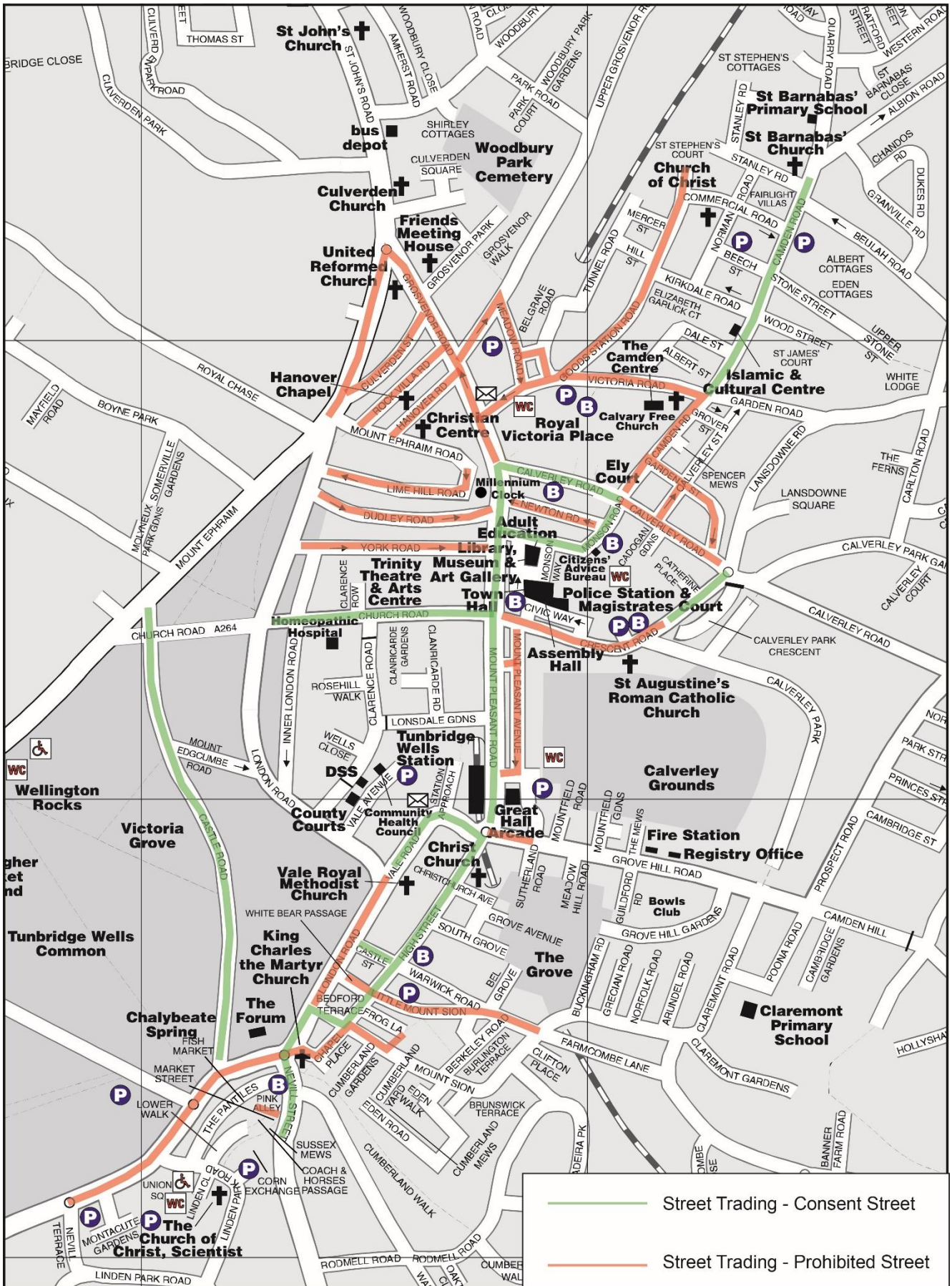

Appendix C- Calverly Precinct – Location of market stall pitches

CALVERLY PRECINCT

Location of Market Stall Pitches

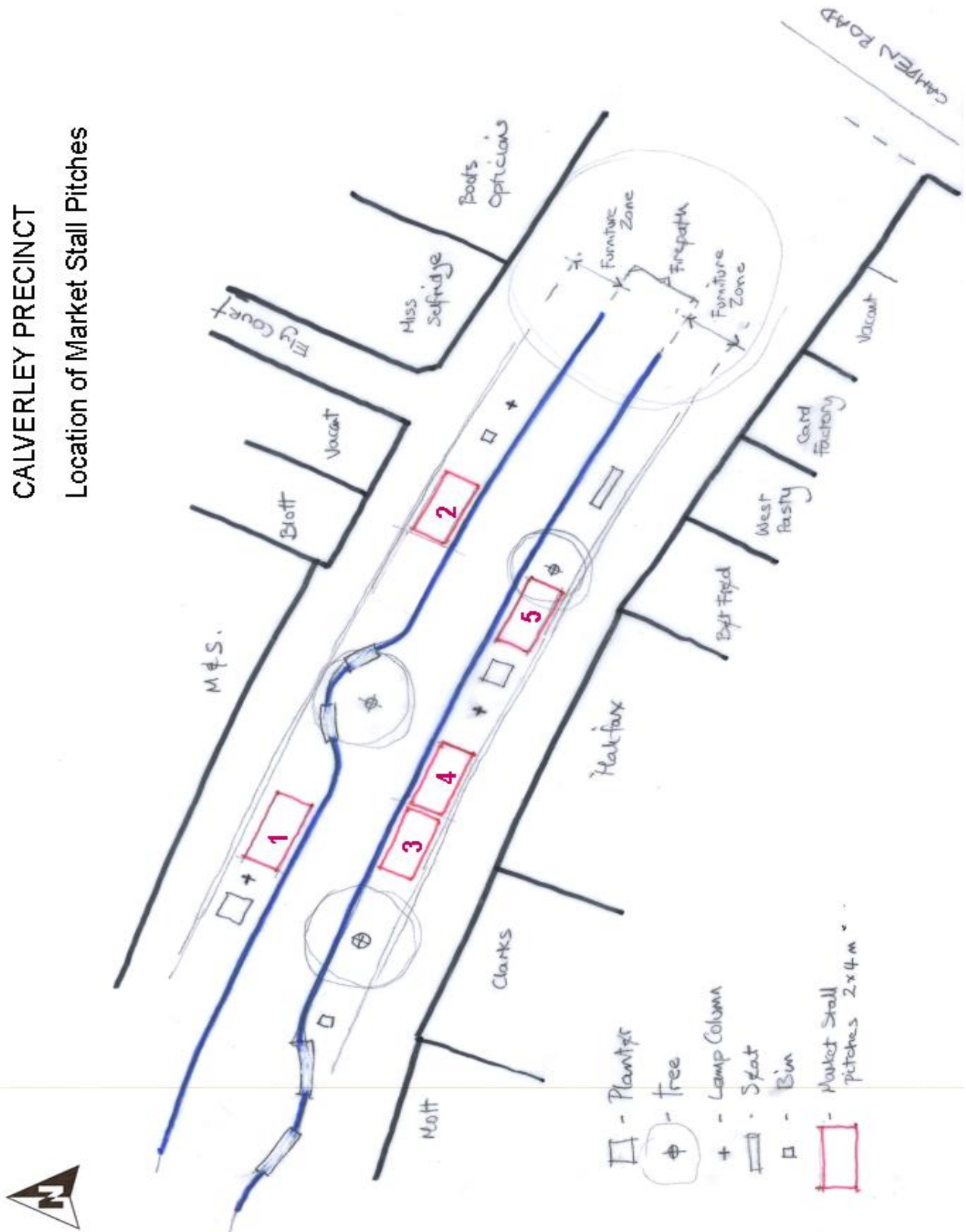

General design guide

The Borough Council has designated 5 market stall pitches which are set out as in the attached plan at the eastern part of the Calverley Precinct.

Locations -

Pitch 1- 35-39 Calverley Road

Pitch 2 – 41-43 Calverley Road

Pitch 3 – 44 Calverley Road

Pitch 4 – 48 Calverley Road

Pitch 5 – 50 Calverley Road

Market stalls shall remain within the confines of the designated pitches and should not obstruct the highway or impede any emergency access. (i.e. the central area)

Market stalls should be a standard traditional type stall or - otherwise as agreed. It is advisable that details of the type and method of construction should be submitted to the Borough Council with the application.

The basic size shall be either 10' (3.0 metres) long, by 4' (1.2 metres) wide, or 12' (3.6 metres) long by 4' (1.2 metres) wide, or as otherwise agreed. **(see below diagram as a guide)**

Covers and canopies should be firmly fixed to the frame and be of suitable materials and discreet colours

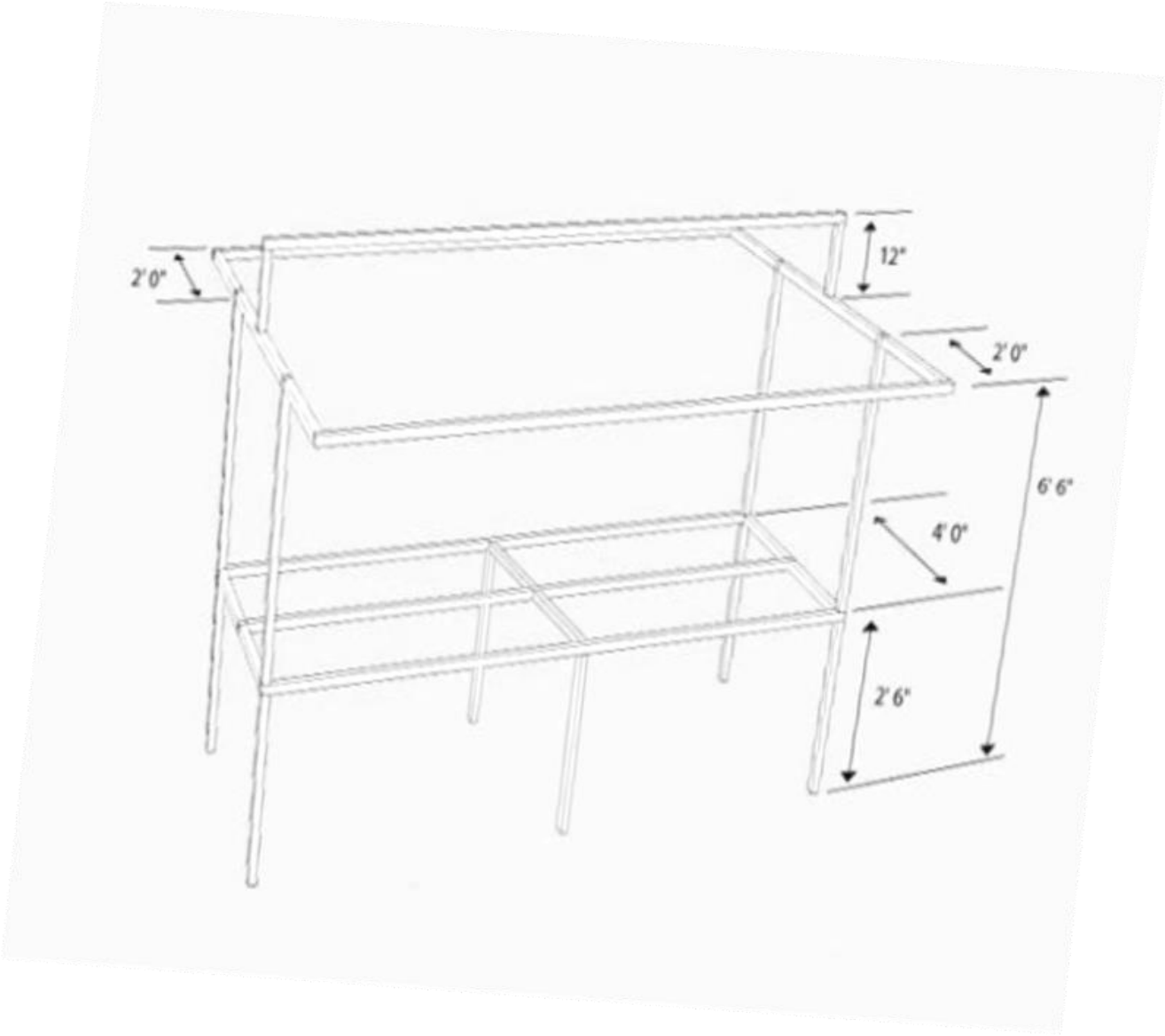

Appendix D – Street trading consents

Guidelines on the relevance of convictions/cautions/warnings

Tunbridge Wells Borough Council has a duty to ensure that a person is deemed suitable to operate as a street trader. The applicant must declare all convictions and cautions at the time of application. Failure to do so may result in the application being refused.

General principles

1. Each case will be decided on its own merits. However, the Council may refuse to grant a street trading consent on any of the following grounds:
 - a. There has been a conviction/caution for an offence involving dishonesty, indecency, certain sexual offences, violence or drugs;
 - b. There has been a conviction/caution for an offence under the relevant licensing legislation;
 - c. Applicant or any entity, or person associated with the applicant has been associated with, have/ have had any outstanding debts owed to the Borough Council; and
 - d. Any other reasonable grounds.
2. If a period of imprisonment, community sentence or Court Order is imposed, the applicant must show a minimum of 3 years has passed without further convictions from the end of imprisonment or sentence, not from the end of any reduced sentence.
3. A person with an unspent conviction as defined in The Rehabilitation of Offenders Act 1974, for serious crime need not be permanently barred from registration but should be expected to remain free of conviction for 3 to 5 years, according to the circumstances, before an application will be considered.
4. Some discretion may be appropriate if the offence is isolated, and there are mitigating circumstances. However, the overriding consideration should be the protection of the public.
5. Where an individual's suitability is called into question, the Senior Licensing Officer will normally determine the matter. In exceptional cases, the matter may be referred to a Licensing Sub Committee for determination, whose decision is final.

Offences involving violence

1. The following examples afford a general guide on the action to be taken where convictions are disclosed, or admitted, but it does not form an exhaustive list:
2. It is imperative that applicants with convictions for offences involving violence are considered carefully. When applicants have convictions for causing grievous bodily harm, wounding or assault, or other more serious offences involving violence, at least five years should normally elapse before an application is considered.

Drug related offences

1. An isolated conviction for a drug offence, whether for unlawful possession - or involving the supply of controlled drugs, need not necessarily debar an individual from registration, usually the applicant will have at least three years free of convictions/cautions or five years since detoxification, if he/she was an addict.

Indecency offences

1. Applicants with indecency or sexual offences would normally be debarred. However, this will depend upon the age and circumstances of the offence, along with any registration on the Sex Offenders Register.

Theft and dishonesty

1. Convictions for isolated minor offences would not normally debar an applicant, but in cases involving serious theft or fraud at least three years should elapse since the conviction or end of any prison sentence, whichever is the longer, before an application is considered. When offences of dishonesty have been accompanied by violence, normally it is considered that at least five years should elapse before an application may be submitted.

Appendix E – Street trading fees

These may be amended from time to time by the Council's Licensing Committee

Application fee – per stall/pitch	£65
Calverly Precinct – per stall/pitch	£26
All other “Consent” streets – per stall/pitch	£26
Street market/event fees – per stall/pitch	£26

Appendix F – Standard conditions that will normally be attached to street trading consent

The Street Trading Consent will be issued by the Council subject to the following conditions, in so far as they do not conflict with or are amended by any specific conditions imposed on the grant of the Street Trading Consent:-

1. The Street Trading Consent shall not operate for any other purpose than to permit the Trader to trade in the Consent Street in accordance with the conditions imposed. The consent holder must ensure that he/she has obtained any other approval or registration required under any other statutory provisions related to their trade.
2. The consent holder shall at all times maintain a valid Third-Party Public Liability Insurance policy to the satisfaction of the Council to the value of five (5) million and shall produce evidence of such insurance any time upon request.
3. The Street Trading Consent is personal to the Trader named within it and shall not be assigned, sub-let or transferred to any other person, firm or company.
4. The Street Trading Consent is valid for the period granted and shall not exceed 12 months.
5. The consent holder shall pay a fee to the Council in accordance with the approved list of fees.
6. The consent holder may surrender the Street Trading Consent at any time, however no refund of the fee will be made.
7. The consent holder must at all times, whilst trading, clearly display the Street Trading Consent issued by the Council.
8. The consent holder or their employee must move the Street Trading unit or vacate the site immediately upon the instruction of a Police Officer / Member of the Emergency Services or duly Authorised Officer of the Council or Highways Authority.
9. The trading shall meet Environmental Health and Trading Standards requirements.
10. The consent holder shall not carry out Street Trading outside the times and days permitted by the Street Trading Consent.
11. The consent holder shall not trade in any location other than the location permitted by the Street Trading Consent.

12. The consent holder shall not sell any type of food, goods or merchandise other than that specified in the Street Trading Consent, unless written permission of the Council has been obtained.
13. The consent holder must be 17 years of age or over and shall be responsible at all times for control of the Street Trading Unit.
14. The consent holder shall not permit any person to assist him/her in his/her trading unless the details of that person have been supplied to the Council and he/she is authorised by the said Council.
15. The consent holders' vehicle movements during the day (on/off site) shall only be as detailed in a written agreement of the Council.
16. Articles placed on the highway should not cause damage to the highway in any way.
17. The consent holder shall be responsible for any damage to the Highway or otherwise, resulting from the Street Trading activity.
18. The consent holder shall not carry on their trade in such a way as to cause obstruction, a nuisance or annoyance or create a danger to pedestrians, persons in the street or to occupiers in the vicinity.
19. The consent holder shall not cause obstruction or encumbrances to current pedestrian flow routes for sighted or visually impaired highway users or those with limited mobility. The numbers of open sides of the permitted trading area shall therefore be limited by the use of a solid barrier edge to provide a tapping rail and containment of the trading area. Formal barriers such as tables and chairs or suitable display stands would be acceptable.
20. A minimum clear passage of 2 meters (facilitating the passing of double-buggies / wheelchairs) around each pitch is required. Where no street furniture (for instance a lamp column, telephone box or guardrail) is present directly in front of a premise an additional 0.8 meters is required to allow for future placing of such items. Where street furniture is already present, the clear width for passage will be measured from the front of the premises to the nearest edge of the item of street furniture.
21. To allow for the safe passage of pedestrians beneath projections, such as canopies, blinds, fascia panels, CCTV equipment and permitted signs, a minimum vertical clearance of 2.75 metres is required from the surface of the footway to the underside of any projection. No such projection is to be permitted to within 1 metre of the nearest carriageway edge, to avoid damage to or by vehicles.
22. The consent holder shall provide and maintain, where appropriate, adequate facilities for the collection of litter resulting from their trade and at the close of each trading day shall remove that litter from the street.

23. The consent holder shall make such provision as is necessary to prevent the deposit in any street of solid or liquid refuse occurring from their Street Trading activity and shall not discharge any waste water to the Street surface or to the surface water drains.
24. The consent holder shall not use any television, tape recorder or other device for the reproduction of sound while Street Trading without the express permission of the Council.
25. If, during the currency of any consent there is any material change in the facts of particulars and information contained in, or submitted with, the application for the consent, the holder of the consent shall report such changes to the Licensing Authority within 72 hours of that change.
26. Any motor vehicle used for the purpose of street trading shall at all times be in a roadworthy condition and possess the relevant documents (insurance, tax and MOT certificates) to prove the legal use of that vehicle on a road. These documents should be produced by the consent holder to any Police Officer or Authorised Officer of the Council, when requested.
27. Neither the consent holder, nor any assistant shall display merchandise which is likely to cause offence or distress to any other person or which would be deemed an offence under any other legislation.
28. A consent holder selling food shall at all times comply with any food hygiene regulations in force at that time, and when required by Council officers, shall produce appropriate food handling certificates.
29. The Council reserves the right to alter or amend these conditions at any time without prior notice to Consent Holders.
30. The consent holder shall ensure that there are adequate fire safety measures in place.
31. The consent holder shall notify the Council in writing of any permanent change of address as soon as practicable. Details of the new address with documentary evidence must be provided (i.e. utility bill, bank statement, etc.).

N.B The consent is issued without prejudice to any other statute, by-law or regulation. The consent does NOT over-ride any regulations regarding parking, food hygiene, obstruction, etc.

FURTHER INFORMATION

For further information in relation to street trading, please contact

Tunbridge Wells Borough Council
Licensing department
Town Hall
Royal Tunbridge Wells
Kent
TN1 1RS
E mail: licensing@tunbridgewells.gov.uk

Telephone: 01892 526 121