

## APPENDIX 18

### HACKNEY CARRIAGE AND PRIVATE HIRE VEHICLES WHEELCHAIRS AND ASSISTANCE DOGS

1. Taxis and private hire vehicles provide a vital service to people with disabilities and medical conditions, and through this policy, we intend to ensure that these services remain accessible to such persons. This aim is supported by relevant statutory provisions within the Equality Act 2010.
2. The Council expects that there shall be no discrimination against taxi or private hire customers, passengers or other members of the public in respect of any protected characteristic, and will seek to take appropriate enforcement action against drivers, operators or vehicle proprietors where complaints of such are substantiated. Dependent upon the severity and circumstances of such incidents, action may include prosecution, or revocation or suspension of licences.
3. We also expect that those working in the taxi trade should not be discriminated against by any other person, and strongly encourage those who are unfortunate enough to be subject to such discrimination to report this to the police for investigation.
4. A wheelchair accessible vehicle would be expected to comply with the dimensions of at least those of a 'reference wheelchair' (see below). Licence conditions will require such vehicles to carry (or be fitted with) loading equipment (ramps or lift), and appropriate restraints and seatbelt fittings to safely secure wheelchairs and their occupants.
5. A 'reference wheelchair' is defined in statute as having the following dimensions:

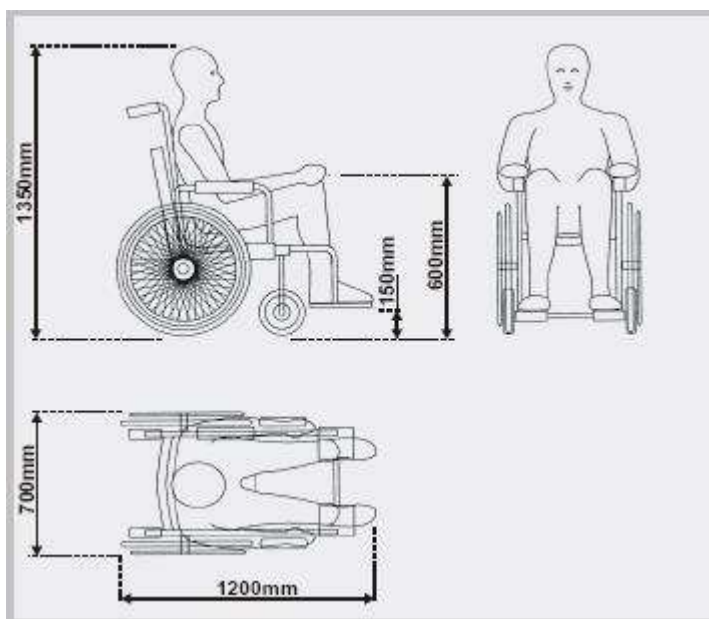

Length:  
1200mm (approx. 48")  
including footplates

Width:  
700mm (28")

Total seated height:  
1350mm (54")

Height of footrest:  
150mm (6")

6. It is anticipated that the above dimensions will cover the majority of manual wheelchairs – however, we recognise that some wheelchairs with specialist functionality, or motorised wheelchairs and mobility scooters, may exceed these dimensions and may not be able to be loaded and carried safely in all designated taxis. In such cases, drivers will be expected to assess whether the passenger can be safely carried in their vehicle, to carry the passenger if their safety and reasonable comfort can be assured, or to assist them in locating a suitable alternative vehicle otherwise, where this is practicable. Such circumstances may constitute a defence to the above-mentioned offence. In all cases, we expect drivers to treat passengers with respect and sensitivity, and to provide a clear explanation as to why they have not been able to convey the passenger.

7. Vehicles which cannot load and carry a wheelchair with the dimensions of the above 'reference wheelchair' are likely to be considered unsuitable for licensing, and an application for such refused.
8. All licensed hackney carriages and private hire vehicles which can safely carry passengers in a reference wheelchair will be designated under section 167 of the Equality Act 2010, from when they are first licensed. This will mean that drivers of those vehicles will have specific legal duties in respect of passengers in wheelchairs, regardless of whether they have hired the vehicle themselves or are accompanying the hirer, to:
  - Carry the passenger while in the wheelchair,
  - Not to make any additional charge for doing so,
  - If the passenger chooses to sit in a passenger seat, to carry the wheelchair,
  - To take such steps as are necessary to ensure that the passenger is carried in safety and reasonable comfort,
  - To give the passenger such mobility assistance as they reasonably require, including assistance:
    - to enable the passenger to get into or out of the vehicle,
    - If the passenger wishes to remain in the wheelchair, to enable the passenger to get into and out of the vehicle while in the wheelchair,
    - to load the passenger's luggage into or out of the vehicle, and
    - if the passenger does not wish to remain in the wheelchair, to load the wheelchair into or out of the vehicle.
9. A driver who fails to comply with any of the above duties without valid defence will commit a criminal offence, and may be fined up to £1,000 for each offence on conviction. Offences may also lead to revocation or suspension of taxi licences.
10. Vehicle proprietors may appeal against designation of their vehicle to a magistrates' court, and further details will be issued with confirmation of designation.
11. A list of designated hackney carriage and private hire vehicles will be maintained and published on our website.
12. Wheelchairs should be secured so as to face either forwards or rearwards. Under no circumstances should an occupied wheelchair be secured with the occupant facing the side of the vehicle.
13. Drivers of designated vehicles may apply to the Council for an exemption certificate, if they have a medical or physical condition which would mean they could not carry out the above duties safely. Further details on how such applications will be considered are set out below. Where an exemption certificate has been issued and the corresponding notice of exemption is properly displayed in the vehicle, the driver will be exempted from such duties as appropriate. Exemptions are specific to an individual driver, and will not provide a defence for any other driver of a designated vehicle.
14. Where a vehicle features mechanical, hydraulic or similar lifting equipment for the purpose of loading and unloading passengers, the Council will have regard to the Lifting Operations and Lifting Equipment Regulations (LOLER), and will require evidence of thorough examination of such equipment by a competent person at least once every 6 months.
15. The following additional conditions will apply to vehicle licences for designated hackney carriages:

- a. Appropriate Wheelchair Tie-down and Occupant Restraint Systems (WTORS) for securing a 'reference wheelchair' and occupant must be carried in the licensed vehicle at all times, and maintained in good order. Equipment should be clearly labelled to show the level/standard to which tested.
  - b. The vehicle must be fitted with or otherwise carry either a ramp or a lift for loading passengers while seated in a 'reference wheelchair', designed for that specific purpose, maintained in good order, and with visible marked reference to a safe working load (SWL) of at least 250kgs and certification to BS 6109 (or equivalent standard).
  - c. All drivers of the licensed vehicle must be trained by the proprietor in the safe usage of the equipment referred to in the preceding paragraphs.
16. Hackney carriage taximeters should not be started until all passengers have been loaded and the driver is ready to commence the journey, and should be stopped upon arrival at the destination, before any unloading activities take place. This is in line with Government guidance, which indicates that running the meter while undertaking statutory duties may constitute making an additional charge for the carriage of passengers in wheelchairs, which is prohibited.
17. The Council currently maintains a published list of designated wheelchair accessible vehicles, which includes both hackney carriage and private hire vehicles where they have met the criteria set out in paragraph 5 ("reference wheelchair") vehicles. **All** current and replacement vehicles that meet this reference standard will automatically be incorporated into the published list s167.
18. Where a hackney carriage or private hire vehicle that is accessible to passengers in wheelchairs, who are able to transfer from their wheelchair into a seat within the vehicle and the wheelchair can be folded down and placed in the vehicle, will be incorporated into the "Voluntary" published list. Drivers, vehicle proprietors and operators of wheelchair-accessible private hire vehicles may face enforcement action which may include suspension or revocation of licences if they are found to have refused to carry or assist passengers in wheelchairs.

### **Passengers with assistance dogs**

19. All licensed hackney carriages and private hire vehicles are required to carry assistance dogs with their owners, at no additional charge. This duty applies in respect of any dogs which are trained to guide or assist a blind person, a deaf person, a person with a disability or a person with a specified medical condition.
20. Private hire operators are also under a duty to take bookings from passengers with assistance dogs, with no additional charge made for carrying the assistance dog.
21. Drivers or operators who fail to comply with the above duties will commit a criminal offence, and may be fined up to £1,000 for each offence on conviction. Offences may also lead to revocation or suspension of licences.
22. These duties apply equally to dogs provided by charities affiliated with Assistance Dogs UK<sup>1</sup>, equivalent overseas organisations, or assistance dogs which have been trained by their owners; and regardless of whether the dog is wearing a recognisable harness or jacket, or subject to formal certification. Where a prospective passenger informs a driver that a dog they wish to travel with is an assistance dog, this should be accepted at face value.
23. Assistance dogs are trained to ride with their owner in the main passenger compartment of a vehicle, usually lying at their feet, and the owner will instruct their dog to enter and exit the

---

<sup>1</sup> See [www.assistancedogs.org.uk](http://www.assistancedogs.org.uk)

vehicle. Passengers with assistance dogs should be asked if they have any preference over which seat they sit in – some may prefer to sit in the front passenger seat of a saloon vehicle, as the larger foot-well can offer more space for the dog to sit in. Drivers should be prepared to provide any other reasonable assistance requested by the passenger; however it is unlikely that assistance dogs will require assistance in entering or exiting most vehicles beyond opening the passenger door. Unless the owner has consented to an assistance dog riding in the back of an estate car, drivers should not try to separate assistance dogs from their owners by insisting that the dog rides in a different part of the vehicle – doing so may cause distress to both the dog and the owner.

24. Assistance dogs are bred and selected for their calm nature, and receive substantial specialist training before beginning their roles. They are subject to regular grooming and veterinary health checks. While we recognise that a number of drivers who are not experienced with dogs may feel uneasy at being in such close proximity to one, this does not constitute valid grounds for refusing to carry a passenger with an assistance dog. Similarly, religious beliefs also do not provide grounds for refusing to carry assistance dogs in taxis and private hire vehicles, nor other legal requirements under UK law<sup>2</sup>.
25. Drivers with a medical condition affected by close proximity to dogs may apply to the Council for an exemption certificate. Further details on how such applications will be considered are set out below. Where an exemption certificate has been issued and is properly displayed in the vehicle, the driver will be exempted from such duties as considered appropriate. Exemptions are specific to an individual driver, and will not provide a defence for any other driver of a vehicle.
26. There is no specific legal duty to carry non-assistance dogs (e.g. pet dogs) or other animals in taxis or private hire vehicles, and doing so will remain at the driver's discretion.

### **Exemption certificates**

27. Drivers of hackney carriages and private hire vehicles may apply for an exemption from one or more of the statutory duties described above, if they have a physical or medical condition which would be incompatible with the exercise of those duties, or if it would be unsafe for them to be required to carry out the duties.
28. The Council expects that the vast majority of licensed drivers will be able to carry out the duties in full, and as such will require evidence of exceptional circumstances to justify the issue of an exemption certificate. As guidance, only a serious condition which would endanger either the safety or wellbeing of the driver, their passenger(s) or the general public if the duties were strictly enforced, is likely to provide sufficient justification for the issue of an exemption certificate.
29. An application form for applying for an exemption certificate is available on request from the Licensing department. This should be completed in full, and submitted with accompanying documents from an appropriate medical professional involved in diagnosis or treatment of the relevant condition, setting out the effect of the condition, the long-term prognosis, and the risk to public safety if an exemption is not granted to the driver. Evidence from a medical professional with no involvement in the diagnosis or treatment of the condition, or from a medical professional with a separate relationship to a driver, is unlikely to be considered acceptable.
30. If the Council is not immediately satisfied as to the justification for an exemption certificate, or if further specific queries have arisen from evidence submitted with the application, the driver

---

<sup>2</sup> "Guidance from the Muslim Shariat Council in 2002 confirmed that trained assistance dogs may accompany disabled people in taxis and private hire vehicles managed or driven by Muslims." [Transport for London, PCO Notice 01/06]

may be asked to undergo an assessment by an independent medical professional appointed by the Council. The costs of this service may be recharged to the driver concerned.

31. Where an allergy or phobia to dogs is cited as grounds for an exemption, we will expect to see evidence of allergen testing results, clinical history, psychological screening results, or similar with an application for exemption. A simple statement that the driver has declared such an allergy or phobia is unlikely to be considered sufficient justification of a medical condition which would warrant the issue of an exemption. A minor allergic reaction which does not affect the driver's ability to safely drive a vehicle or their overall welfare is also unlikely to warrant an exemption.
32. Exemption certificates will typically be issued for a fixed period. For a temporary physical or medical condition, this will usually follow advice from the medical professional as to the likely duration of the condition. A driver granted a lifelong exemption may be subject to a requirement for reassessment at the discretion of the Licensing Officer.
33. In accordance with the Statutory Regulations, a Notice of Exemption must be exhibited in the prescribed manner while the exempted driver is using it:-
  - a) by displaying it-
    - i. On the nearside of and immediately behind the windscreen of the vehicle; and
    - ii. In a manner that readily permits its removal;
  - b) so that-
    - i. its front is clearly visible from the outside of the vehicle; and
    - ii. its back is clearly visible from the driver's seat of the vehicle

When we grant an exemption, we will issue a laminated sign inside a plastic pouch which should be affixed as above, plus a paper certificate of exemption which should be carried in the vehicle with all other paperwork required under the vehicle licence conditions. If a notice is not being displayed and the driver refuses to provide assistance or carry an assistance dog (as applicable), they may be prosecuted or face other enforcement action. Exemption Notices/certificates must be removed if the vehicle is to be driven by another driver.

34. If an application for an exemption certificate is refused, the applicant concerned may appeal against that decision to a magistrates' court within 28 days beginning with the date of the refusal, and further details will be issued with the refusal notice.

---

## Further information

The following materials may provide further information on this subject:

Assistance Dogs: A guide for all businesses (Equality & Human Rights Commission)  
[https://www.equalityhumanrights.com/sites/default/files/assistance-dogs-a-guide-for-all-businesses\\_0.pdf](https://www.equalityhumanrights.com/sites/default/files/assistance-dogs-a-guide-for-all-businesses_0.pdf)

Access to taxis and minicabs for guide dog owners (Guide Dogs)  
<https://www.guidedogs.org.uk/media/8240022/access-guide-taxis.pdf>

Top Tips for Taxi Drivers (Guide Dogs)  
<https://www.guidedogs.org.uk/media/8239809/8159-top-tips-for-taxi-drivers-a5-flyer-no-bleed.pdf>

